

STILT FLOOR PLAN

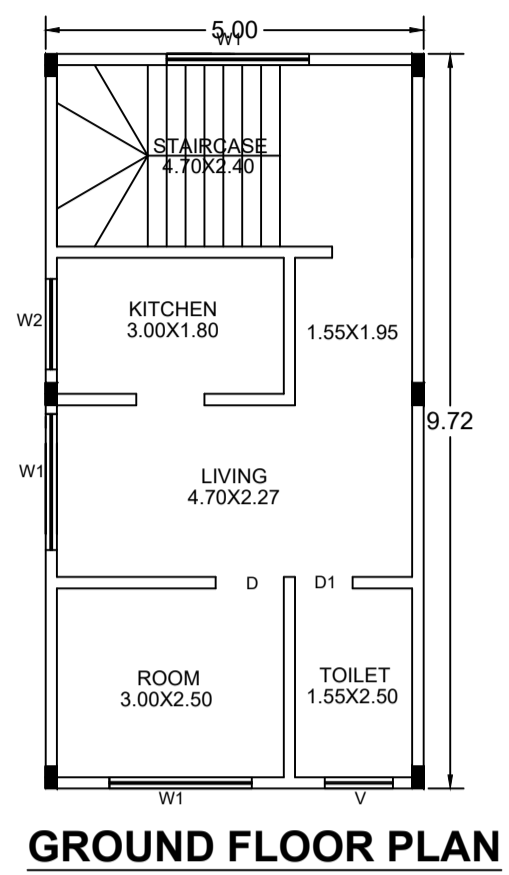

GROUND FLOOR PLAN

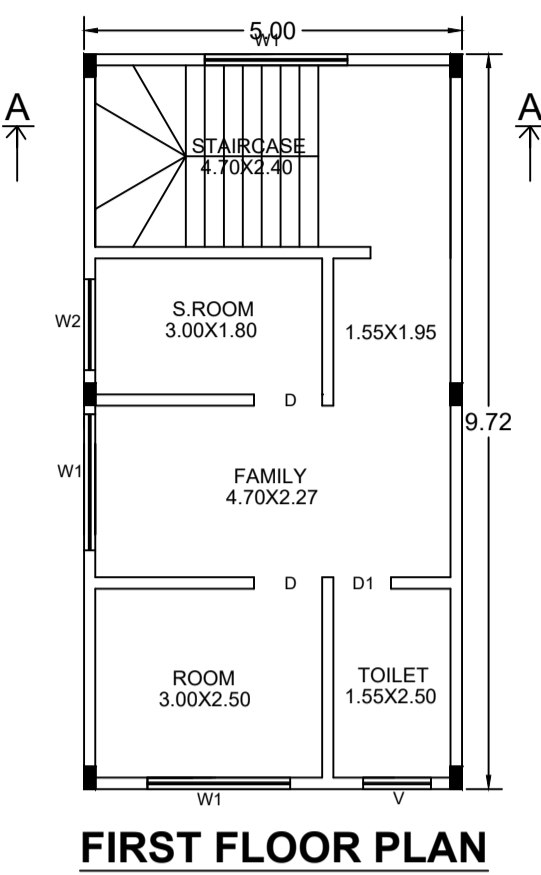

FIRST FLOOR PLAN

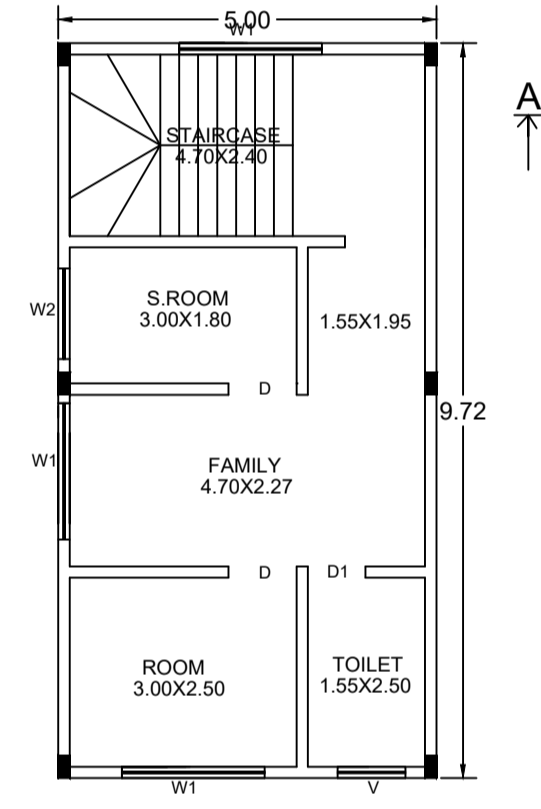

SECOND FLOOR PLAN

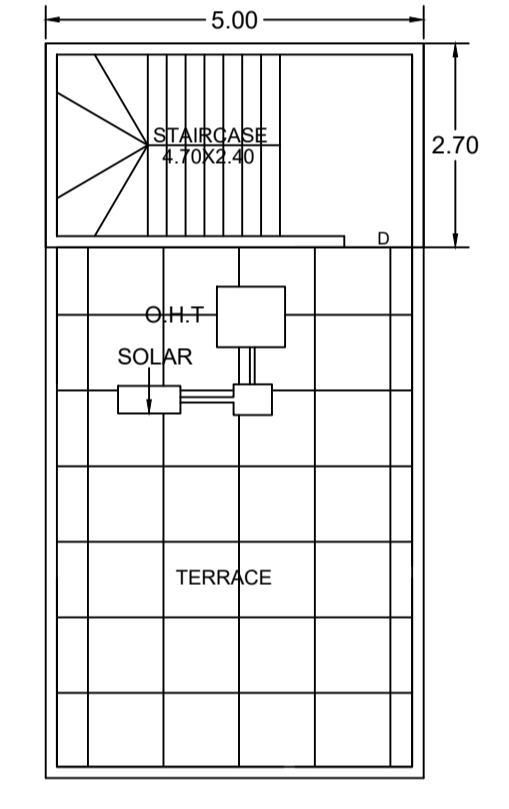

TERRACE FLOOR PLAN

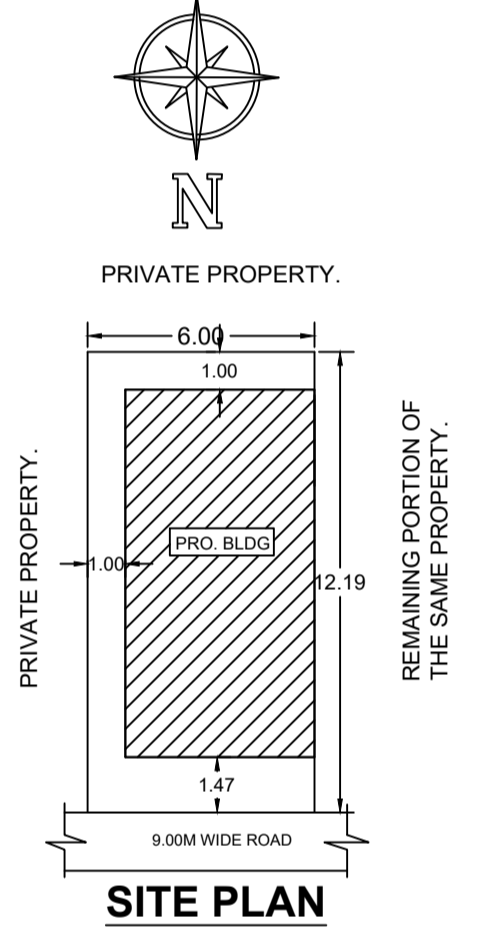

SITE PLAN

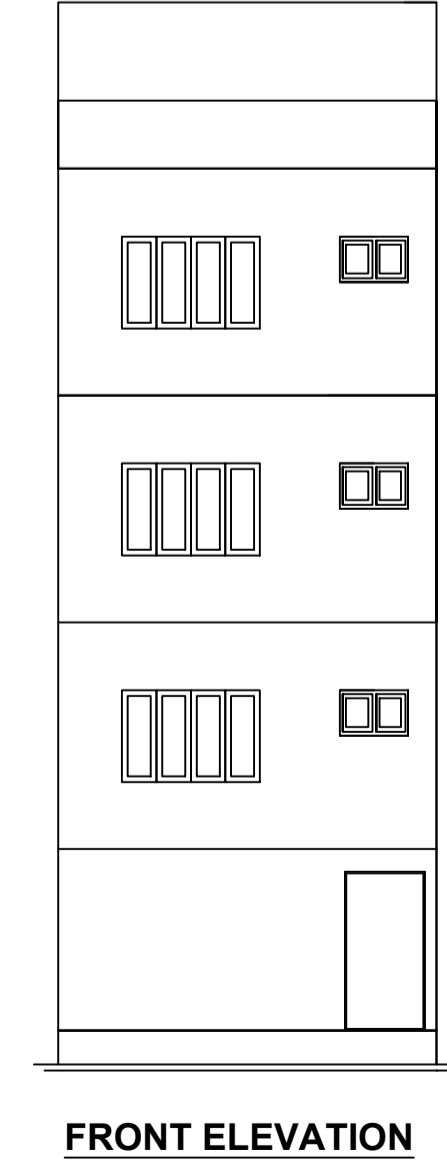

FRONT ELEVATION

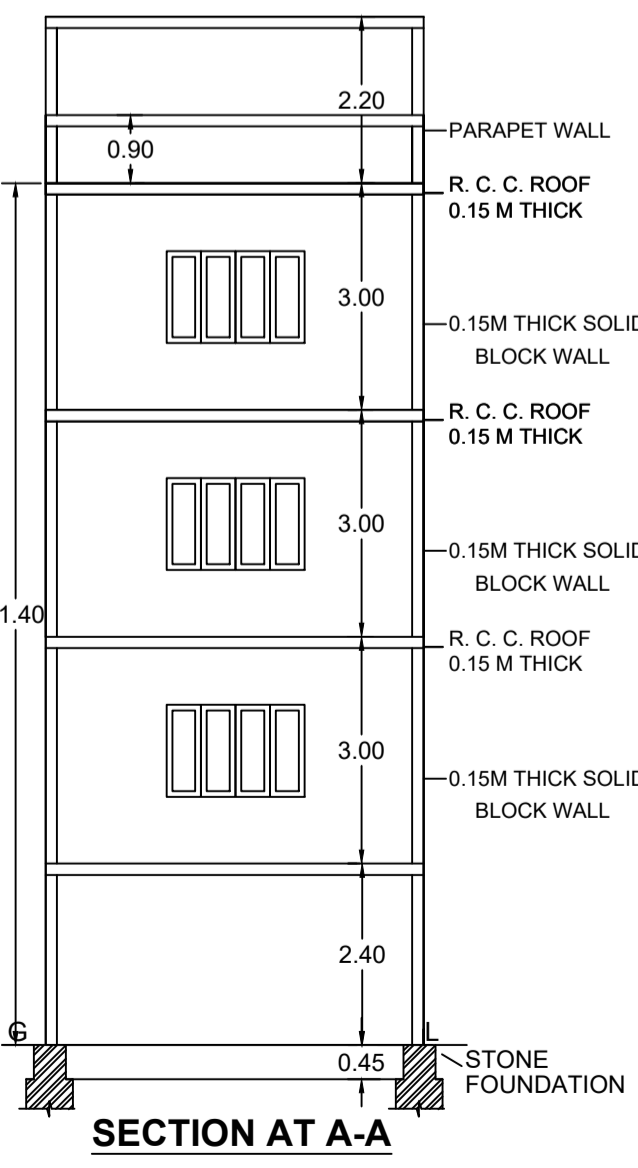

SECTION AT A-A

Color Notes

COLOR INDEX

Table with 2 columns: Color Name and Description. Includes Plot Boundary, Abutting Road, Proposed Work, Existing, and Existing to be demolished.

AREA STATEMENT (BBMP) table with columns: AREA OF PLOT, NET AREA OF PLOT, COVERAGE CHECK, FAR CHECK, BUILT UP AREA CHECK. Includes sub-totals for various categories.

Approval Condition: This Plan Sanction is issued subject to the following conditions: 1. The sanction is accorded for... 31. Sufficient two wheeler parking shall be provided as per requirement... 46. Also see, building licence for special conditions, if any...

Block 'A (A)' table with columns: Floor Name, Total Built Up Area, Deductions, Proposed FAR Area, Total FAR Area, Tmnt (No.).

UnitBUA Table for Block 'A (A)' table with columns: FLOOR, Name, UnitBUA Type, UnitBUA Area, Carpet Area, No. of Rooms, No. of Tenement.

FAR & Tenement Details table with columns: Block, No. of Same Bldg, Total Built Up Area, Deductions, Proposed FAR Area, Total FAR Area, Tmnt (No.).

SCHEDULE OF JOINERY: BLOCK NAME, NAME, LENGTH, HEIGHT, NOS. Table with 5 columns.

SCHEDULE OF JOINERY: BLOCK NAME, NAME, LENGTH, HEIGHT, NOS. Table with 5 columns.

Parking Check (Table 7b) table with columns: Vehicle Type, No., Area (Sq.mt.), Achieved. Includes Car, Total Car, TwoWheeler, Other Parking.

Required Parking (Table 7a) table with columns: Block Name, Type, SubUse, Area, Req'd, Units, Car, Prop.

Block USE/SUBUSE Details table with columns: Block Name, Block Use, Block SubUse, Block Structure, Block Land Use Category.

Approval Date :

OWNER / GPA HOLDER'S SIGNATURE: VENKATESH.M

ARCHITECT/ENGINEER /SUPERVISOR'S SIGNATURE: KIRAN KUMAR DS

PROJECT TITLE: PLAN SHOWING THE PROPOSED RESIDENTIAL BUILDING AT SITE NO:102/5 (EASTERN PORTION), KATHA NO:519/519/1, KODIGEHALLI VILLAGE, YELAHANKA HOBLI, WARD NO.08, BANGLORE.

DRAWING TITLE: 115627669-03-08-202111-40-315\_ \$20X40 VENKATESHA DWG : A (A) with STILT, GF+2UF

SHEET NO : 1

SANCTIONING AUTHORITY table with columns: Assistant Engineer/Town Planner, Assistant Director, YELAHANKA.